

# **Micro Hydraulic Generator**

## **Barrel Turbine**

**TS-LZ-40-6KW**

---

# User Manual

---

Ver1.1



**Bringing you a prosperous future with  
clean, reliable and renewable energy.**

# Catalogue

<b>I IMPORTANT SAFETY INSTRUCTIONS .....</b>	<b>03</b>
<b>II Main Technical Performance Parameters.....</b>	<b>04</b>
<b>III Summary .....</b>	<b>05</b>
1. Key Technical Data.....	07
2. Station Site and Installation.....	07
3. Operation Method.....	11
4. Maintenance.....	12
5. Service Rule.....	12
6. Routine Faults Treatment.....	13
7. Quick-wear part.....	14
Appendix I .....	15
Appendix II .....	16
Appendix III .....	17
Appendix IV .....	18

## **I IMPORTANT SAFETY INSTRUCTIONS**

This manual contains important instructions that shall be followed during installation and maintenance of the *TS-LZ-40-6KW*.

To reduce the risk of electrical shock, and to ensure the safe installation and operation of the *TS-LZ-40-6KW*, the following safety symbols are used to indicate dangerous conditions and important safety instruct

	<p><b>WARNING:</b> This indicates a fact or feature very important for the safety of the user and / or which can cause serious hardware damage if not applied appropriately. Use extreme caution when performing this task.</p>
	<p><b>NOTE:</b> This indicates a feature that is important either for optimal and efficient use or optimal system operation.</p>

Business  by the National Quality Supervision

## II Turgo Turbine Unit Main Technical Performance Parameters

Main Specifications		
Turbine		Remarks
Type	TS-LZ-40-6KW	Turgo Turbine
Rated Head	3.0m	
Rated Flow	378 l/s	
Power	6KW	
Efficiency	60%	
Generator		Remarks
Type	SF-6-4/430	Conforms to the IEC international electrician
Rated Power	6.0 KW	
Rated Voltage	230VAC	

Rated Current	26 A	committee standard	
FQCY	50Hz		
Rated Rotational	1500 r/min		
Phase	1		
P.F.	1.0		
Altitude	≤ 3000m		
Insulation Grade	B/B		
Antisepticise Grade	IP44		
Ambient Temperature	- 25°C ~ + 50°C		
Relative Humidity	≤ 90%		
<b>Control Panel</b>			<b>Remarks</b>
Safety Protection	Short circuit Protection		
	Islanding Protection		
	Over Load Protection		
	Grounding Fault Protection		
Packing Material	Fiberboard		
Packing Size	× × cm		
Packing Weight	Net	kg	
	Gross	kg	
Stated: This product presents or the technical parameter revision, is the technical improvement result, no other explanation.			

**Note: The modification of the product appearance or technical parameters, which is a result of technique improvement, Will not be announced additionally.**

### III Summary

Greet you to use TS series of micro hydro generator unit. This series of generator unit consists of the TS series of turbine and SF series of Rear Earth Permanent Magnet brushless synchronization generator, which includes 5 types of single and three phases generator unit whose power output is from 3KW to 10KW. The user can chose the type fits for the amount of coulomb and the flows of the water head.

The series of units is provided with the automatism control voltage and

frequency. The user can turn on or off the electric appliances (TV sets, recorders, etc) as wish on condition that the amount of coulomb does not exceed the nominal power output, and the user will feel it as convenient as the electrical net.

Before you use the generator units, please make sure that you read this instruction manual carefully. And you choose the installation position of units, ditch construction, the inlet conduit installation, the electrical wire span and the adjustment of generator unit by the direction of the professional.

After the generator unit can work continuously or in preset time, you had better arrange the career man to do some manage work and maintenance according to the instruction manual and the safety electrical precautions.

## 1) Micro Hydro Station General Description

The typical micro hydro generator station is as follows (figure 1), which consists of earthwork (inlet conduit construction, unit room and drain etc), the micro hydro generator, electrical wires and the users wires.

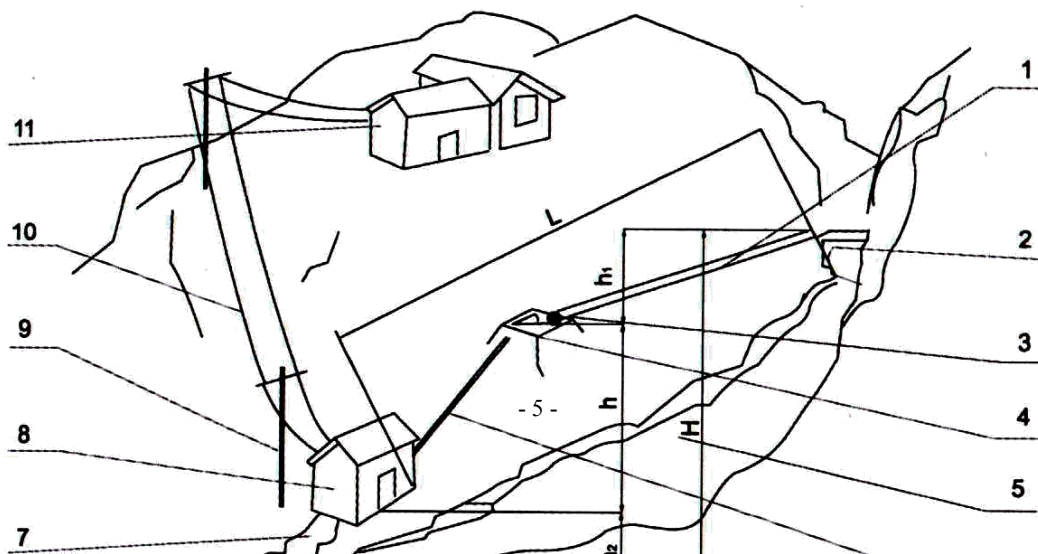

Figure1: The project of micro hydro generator using pipe

01	Penstock	06	Inlet Pipe	11	User
02	Reservoir	07	Tailrace	h	Water head
03	Trash rack	08	Power house	h1	Penstock fall
04	Fore bay	09	Electric pole	h2	Flood altitude
05	Brook	10	Wire	H	Reach fall

The work process is as follows: Collecting the water of stream by reservoir, the water inflow the pressure poor through the inlet conduit, the go into the micro hydro generator which is installed in the unit room through the inlet pipeline, force the runner to circumgyrate, which drives the generator to generate electricity. At eh same time, the adjustment machine auto adjust the vottage and the frequency to meet the requirements for power supply, and then the user can use the electricity transmitted electrical wires.

2) This kind of Micro-hydro Generator is consisted of an inclined impulse turbine and a set of direct connected AC single-phase / three-phase generator. With the characteristics of small body, lightweight, simple structure, reliable operation and convenient assembly, and serving as the power source of lighting, TVs and recorders, it is most suitable for the households in mountain areas with scattered and small hydroelectric sources. The consumers can do easily themselves the installation and operation. This product has been thoroughly strengthened in the

special technical measures to good quality, stable function and easy operation for women and children. Much less investment may add more happiness to your family.

## **1. Key Technical Data:**

**Water Head for installation:**2.5m

**Flow (m<sup>3</sup>/s):**0.45

**Output Voltage (v):** 230V(AC)60HZ

**Output Power (kw):** 6

## **2. Station Site and Installation:**

### **(1) Power site selection**

The generic condition for selected power station site may show from the following four aspects:

1.1 The Selected power station site must be able to use the hydro energy economically, it is necessary to meet the cost-saving principles. Generally the requested head is not lower than 2.5 meters.

1.2 In selected power station sites, topography, geological and hydrological conditions should be relatively superior, but also in the design and construction also is feasible. The construction of micro-hydropower station in the building materials (such as gravel, etc.) using, it should conform to the principle "obtain raw materials locally" as far as possible.

1.3 The selected power station site is requested to approach as close as possible

to the power supply and processing region, in order to reduce the electric transmission equipment's investment and the electric power loss, and also it is advantageous for the short distance management. The suitable choice is to install the turbine in the place where is drainage conveniently and not to be destroyed and submersed by the mountain torrents. If the hydroelectric power station site is selected on the hillside, you should equip the facility to against mountain torrent and the rolling stones.

1.4 The selected power station sites should make full use of existing hydraulic structures. For example, irrigation canal's falling water or irrigation reservoir's flow and so on.

## **(2) Construction of the pressure forebay**

The pressure forebay, "forebay" for short., is a pool which is connected between the irrigation conduit and a pressure pipe. The forebay is composed of the reservoir, the trash rack, the gate, the overflow and so on.

2.1 In micro-hydropower station, the forebay has the following several functions:

2.1.1 The forebay can lead the water from the water diversion canal inflow to the pressure piping. If there are several turbine units, and also supply water to these various pressure piping separately, it will be allocated enough water to these various pressure piping.

2.1.2 Using trash rack to prevent tree roots, weeds and silt in the irrigation conduit to enter the pressure piping and hydraulic turbine, in winter, it can prevent the entrance of pressure piping freezing.



2.1.3 It can prevent the current of water to enter the pressure piping, when the pressure piping or the hydraulic turbine have an accident or need maintenance.

2.1.4 It can adjust the water volume in a short time when the unit is started up or the load is changed, the upstream water level changing scope is small. If the available water current capacity is insufficient, you can use the forebay to store water in the daytime and generate electricity at night.

2.1.5 It can discharge the unnecessary water through the overflow gate to maintain the normal water levels and steady the head of hydroelectric power station.

2.1.6 It can deposit the silt in the canal to reduce wear and tear of turbine.

2.2 Matters need attention before forebay construction:

2.2.1 The forebay's position should base on the position of pressure piping and the workshop's position. Choose a stable and solid foundation, small water-permeable place which is close to workshop.

2.2.2 The forebay should have a certain volume and water depth. When the load of power plant changes, it should be able to make the forebay's water level fluctuated to be smallest and should meet the requirements of sinking sand.

2.2.3 The aerial drainage ability of the forebay's overflow gate ought to be able meet drain the maximum current capacity when all turbines rejected all load.

2.2.4 When you install the unit, you must certainly set up a trash rack in the water inlet, the hole of trash rack's size is generally 1/3 of the hydraulic turbine nozzle's to guarantee that sundries into the hydraulic turbine will not stop up the nozzle.

2.2.5 The size of trash rack should be three times than pressure pipe's mouth size. Its function is to guarantee there is enough water to make the turbine work normally and reduces the cleaning times when the trash rack of pressure pipe mouth is partly blocked by sundries.

2.2.6 You should install the second trash rack at the entrance of forebay if there are many sundries in the canal. You must clean up the sundries on the trash rack frequently when the unit is running.

2.2.7 When you install the trash rack in the forebay, it's inclination need to be  $30^{\circ} \sim 60^{\circ}$ . If you arrange it  $90^{\circ}$ , it's easy to be blocked by sundries.

4) The base structure may be built from local material. You can make a round hole which has the diameter as same as the lower inner circle of the turbine frame by using cement, wood-board, etc, and fasten it in screw or round nail, also it should be positioned horizontally. The surface of drainage must be away from the bottom of base for 20-30cm. It must be covered with proper shelter to prevent from raining and sunlight when the unit is installed outdoors.

### **3. Operation Method:**

1) Firstly, check whether all components are completed and the intake of penstock is blocked.

2) Then check whether the runner of turbine can be easily rotated, and rotated in by hand to ensure the voltage meter has readings (put the output switch in OFF position).

3) For the first starting, the output switch should be put in the voltage-stabilized control position (A), then open the gate to let water out from small to large, observe the readings meter till 230v or so continue enhancing water volume, the voltage device is reliable if the reading keep still. At this time the load can be connected, then adjust the water volume to hold the output of 230v or so. Once the stabilizing device break down, put the switch in B, then the voltage of unit will be under manual-controlled, you may follow the next procedure to control by valve.

4) During the operation, the load should be kept stable as possible as can be. Don't shut off the load suddenly, or else the high voltage will burn out the rest load, if you must is connect the load, you may decrease water to small volume at first, then disconnect the most part of load when the voltage has dropped to below 230v (you must do as this even you run the unit under the using of voltage-stabilizing device).

5) It need only close the valve to switch off the unit when the load has been stable after first operation, the power switch may hold on so that you may adjust voltage up to 230v directly for next running.

#### **4. Maintenance:**

1) To check and clean the mud and foreign material blocking in the intake house and trash rack.

2) The frame of unit should be injected water-proof grease by using grease cup in every three month, each time rotating for three times. The upper bearing also

Faults	Cause and treatment
Low water volume when switch on the unit. The generator cannot be started.	1. There is foreign material blocking the nozzle. Clear it. 2. Open the valve to reject air.
The voltage meter display reading, but the	The fuse has been burned out, replace it

should be added waterproof grease for every six months.

3) The generator must be conducted the dry treatment before next start if it became wet.

#### **5. Service Rule:**

1) When the unit breaks down, please handle it according to the Routine Faults Treatment List if only it has a slight error; please send it to professionals or manufacturer if it must be dismantled.

2) We will be responsible for the three guarantees of the unit for its quality faults during the first year's operation. If its damage is due to the customer's misuse, we may repair it on the condition of proper fee paid by user.

3) We guarantee a long stable period of the spare-parts supplying.

#### **6. Routine Faults Treatment:**

indicator and load lamp does not light.	
Voltage can not be rose up	1.The water volume is too low, increase it 2.Reduce the heavy load
The fuse is burned out	Short-circuit. Check and repair it.
The load cannot be entirely carried.	The drop is too low. Replace the nozzle by a larger one if water volume is proper.

### 7. Quick-wear part:

Item	Specification
1.Single-row radial ball bearing in lower end cover	6KW---605
2. Single-row radial ball bearing in upper end cover.	6KW---605
3. Water closing	P45

## Appendix I

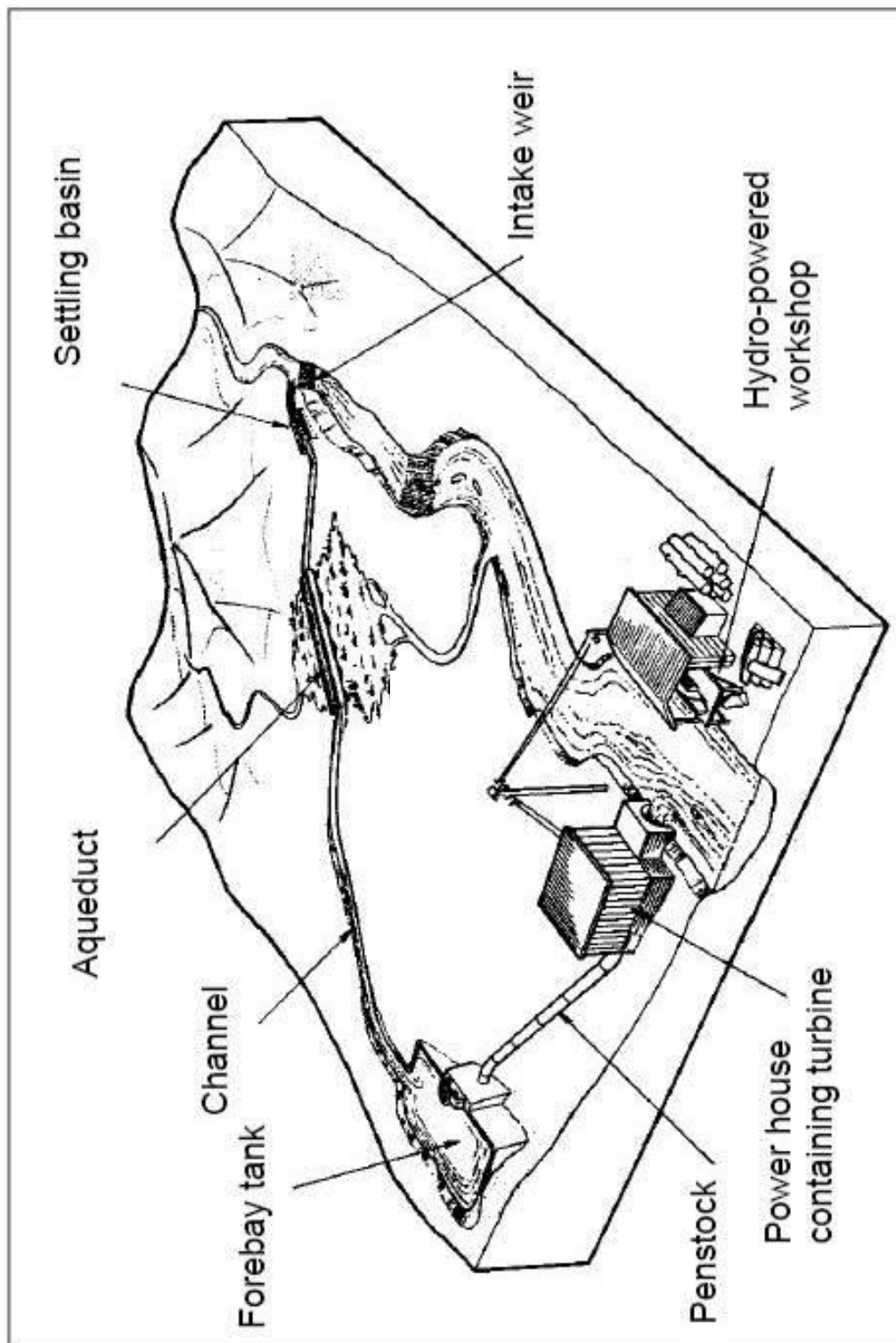

## Appendix II

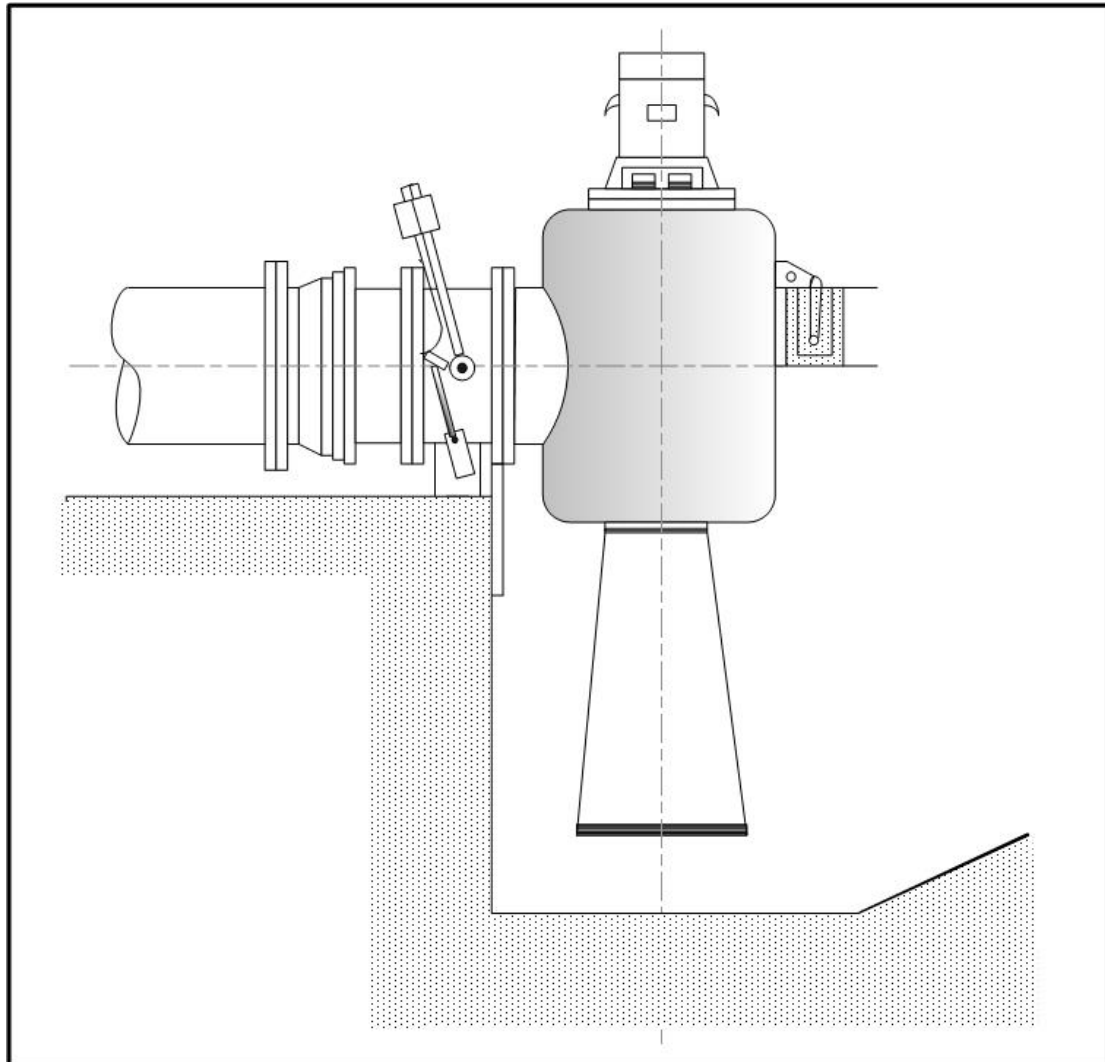

### Appendix III

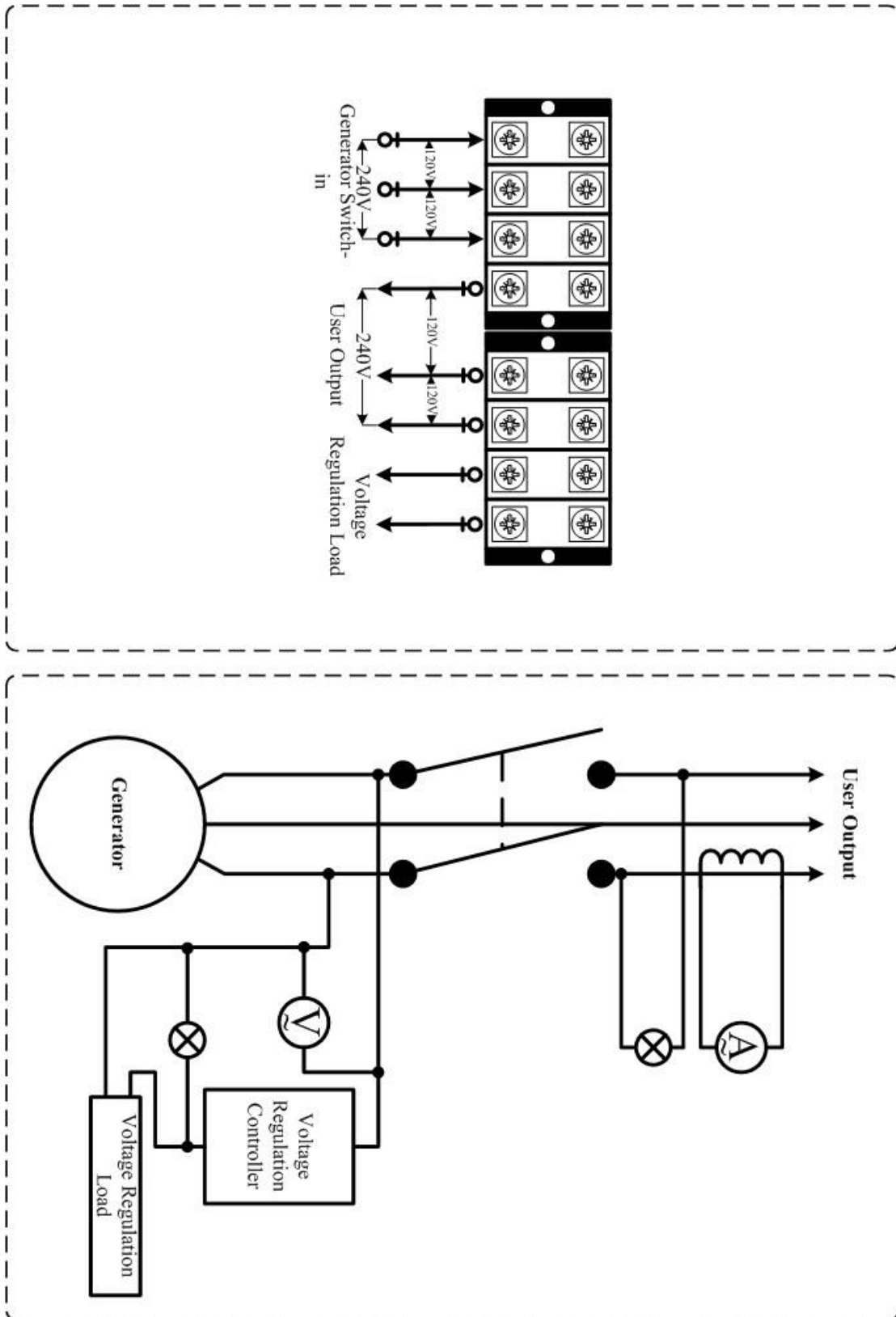



## Appendix IV

### Add lubricant

